

SPECIFICATIONS

DIAMETER:	12" (304.8 mm)
SENSITIVITY (2.83 V @ 1 m):	93 dB
POWER HANDLING:	300 W _{RMS}
FREQUENCY RESPONSE:	18 ~ 500 Hz
NOMINAL IMPEDANCE:	4 OHMS
VOICE-COIL DIAMETER:	2.0" (50.7 mm)

DIMENSIONS:

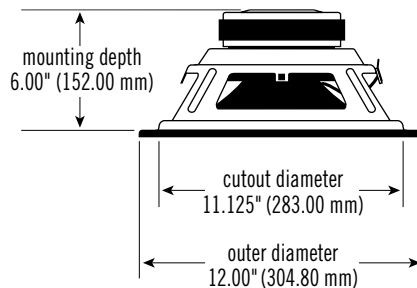

THIELE-SMALL PARAMETERS

VOICE COIL DC RESISTANCE:	R_{EVC} (OHMS)	3.29
VOICE COIL INDUCTANCE @ 1 kHz:	L_{EVC} (MH)	1.12
DRIVER RADIATING AREA:	S_D (IN ²)	82.46
	S_D (CM ²)	532.00
MOTOR FORCE FACTOR:	BL (TM)	10.65
COMPLIANCE VOLUME:	V_{AS} (FT ³)	4.99
	V_{AS} (LITERS)	141.40
SUSPENSION COMPLIANCE:	C_{MS} (µM/N)	351.81
MOVING MASS, AIR LOAD:	M_{MS} (GRAMS)	116.87
MOVING MASS, DIAPHRAGM:	M_{MD} (GRAMS)	109.82
FREE-AIR RESONANCE:	F_S (Hz)	24.82
MECHANICAL Q:	Q_{MS}	8.42
ELECTRICAL Q:	Q_{ES}	0.53
TOTAL Q:	Q_{TS}	0.50
MAGNETIC-GAP HEIGHT:	H_{AG} (IN)	0.31
	H_{AG} (MM)	7.92
VOICE-COIL HEIGHT:	H_{VC} (IN)	1.25
	H_{VC} (MM)	31.75
MAXIMUM EXCURSION:	X_{MAX} (IN)	0.47
	X_{MAX} (MM)	11.91

SEALED BOX VOLUME (INCLUDES DRIVER DISPLACEMENT)

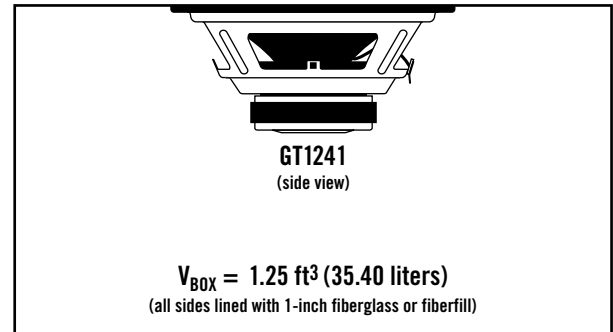

SEALED FREQUENCY RESPONSE @ 2.83 V

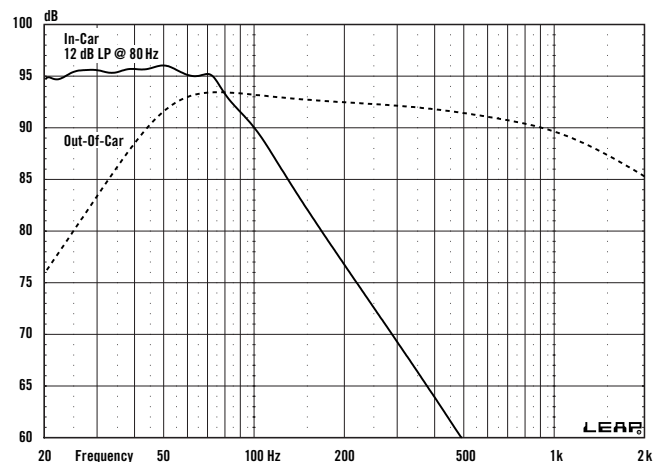

SEALED EXCURSION/GROUP DELAY @ 300 W

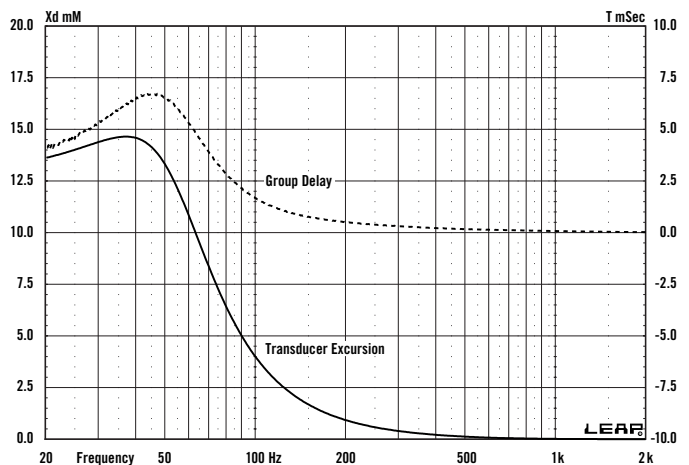



GT1241 12" Woofer – Technical Data

VENTED BOX VOLUME (INCLUDES DRIVER/PORT DISPLACEMENTS)

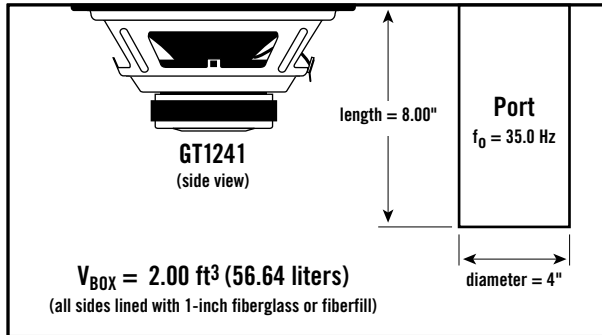

SEALED BANDPASS BOX VOLUME (INCLUDES DRIVER/PORT DISPLACEMENTS)

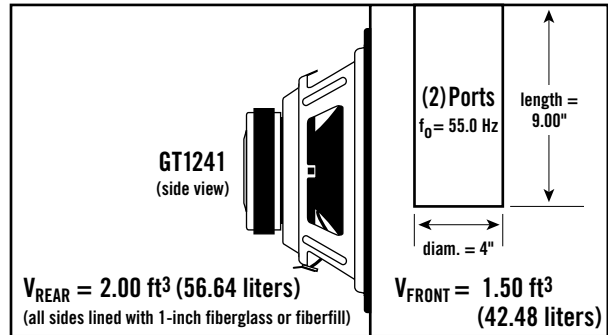

VENTED FREQUENCY RESPONSE @ 2.83 V

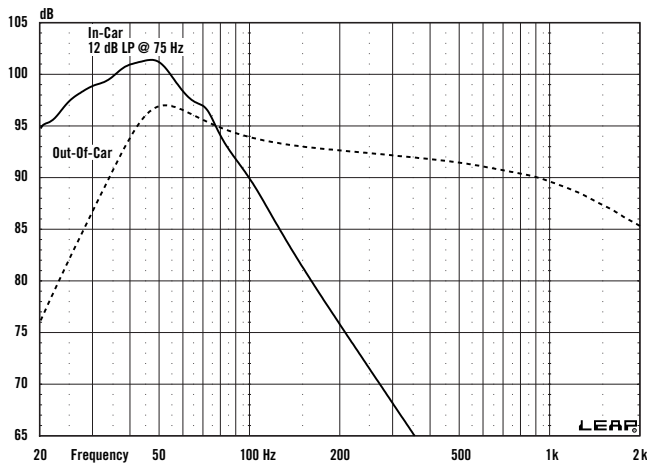

SEALED BANDPASS FREQUENCY RESPONSE @ 2.83 V

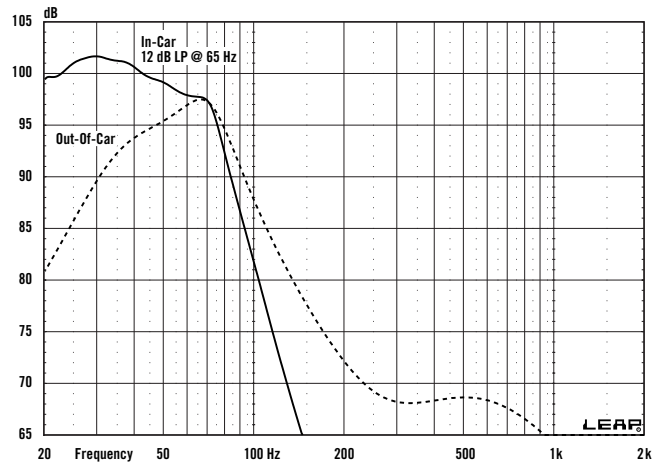

VENTED EXCURSION/GROUP DELAY @ 300 W

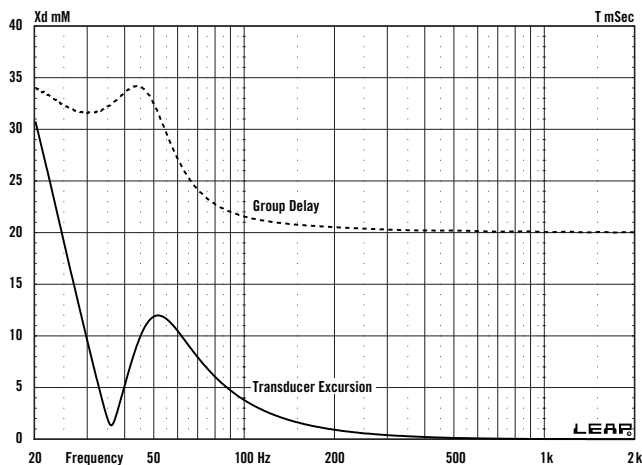

SEALED BANDPASS EXCURSION/GROUP DELAY @ 250 W

